

Technical sheet :

TMT 251ST5



Technical characteristics		Metric	
1.1	Manufacturer		MANITOU
1.2	Model Name		TMT 251 ST5
1.2.1	Reach out equipment		Telescopic boom
1.3	Power source		Diesel
1.4	Operator type		Sitting
1.5	Max. capacity	Q	2500 kg
1.6	Load centre of gravity	c	500 mm
1.8	Load distance, centre of drive axle to fork	x	-505 mm
1.9	Wheelbase	y	1784 mm
Wheels			
3.1	Tyres type		Pneumatic
3.2	Dimensions of front wheels		18x7-8
3.3	Dimensions of rear wheels		10x16,5
3.5	Number of front wheels / rear wheels		2 / 1
3.5.2	Drive wheels (front / rear)		2 / 1
3.6	Front wheel gauge	b10	2102 mm
Dimensions			
4.2	Height telescopic boom lowered	h1	2285 mm
4.3	Free lift	h2	1700 mm
4.5	Height telescopic boom extended	h4	3925 mm
4.7	Height of overhead guard (cabin)	h6	2200 mm
4.8	Seat height/stand height	h7	1220 mm
4.19	Overall length	l1	2455 mm
4.21	Overall width	b1	1270 mm
4.22	Forks section / width / length	s / e / l	40 mm x 125 mm / 1200 mm
4.23	Fork carriage ISO 2328 (class/form) A/B		FEM 2A
4.24	Fork carriage width	b3	1270 mm
4.26	Distance between wheel arms/loading surfaces	b4	1634 mm
4.28	Maximum horizontal extension at COG 600	l4	2100 mm
4.32	Ground clearance at centre of wheelbase	m2	278 mm
4.37	Overall length (without forks)	l7	1590 mm
4.34	Aisle width for 800 x 1200 pallet lengthways	Ast	3970 mm
4.35	Turning radius	Wa	3011 mm
4.36	Internal turning radius (over tyres)	b13	269 mm
Performances			
5.1	Travel speed (laden / unladen)		11 km/h / 11 km/h
5.2	Lifting speed (laden / unladen)		0.24 m/s / 0.25 m/s
5.3	Lowering speed (laden / unladen)		0.29 m/s / 0.31 m/s
5.10	Service brake		Hydraulic brakes by loss of pressure
5.9	Acceleration time (laden / unladen)		4.90 s / 3.80 s
Engine			
7.1	Engine brand / norm		Kubota - Stage V
7.2	Engine power according to ISO 1585		37 kW
7.3	Rated speed		2700 rpm
7.4	Number of cylinders / Capacity of cylinders		3 - 1826 cm³
8.1	Type of drive control		Mechanical
7.5	Fuel consumption according to VDI cycle		5.60 l/h
Miscellaneous			
8.2	Working hydraulic pressure for attachments		270 bar
8.3	Oil flow rate for attachments		50 l/min
8.4	Measured/guaranteed mean noise level at the ear of the operator		104 dB
8.4	Sound level at the driver's ear according to DIN 12 053		83 dB

TMT 251 ST5 - Dimensional drawing

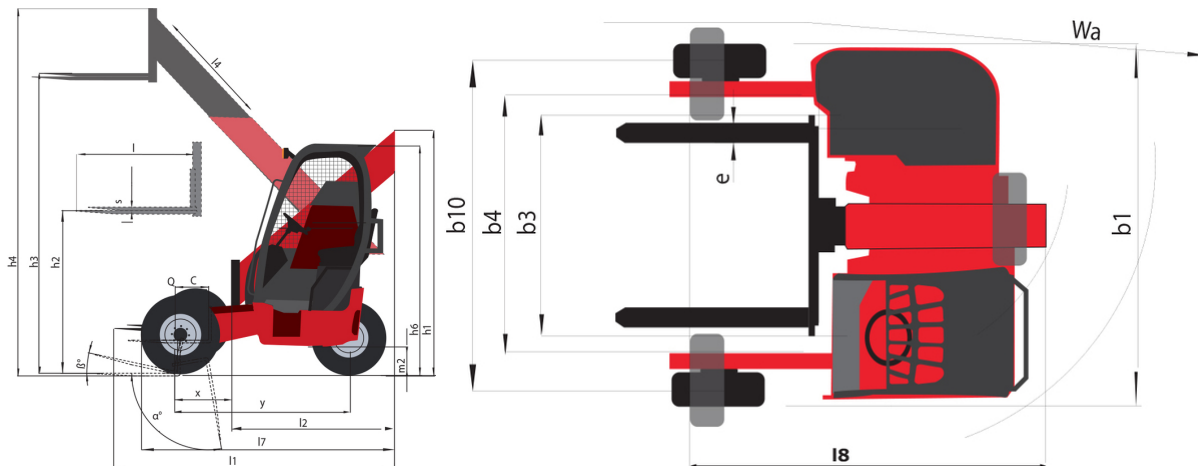

TMT 25I ST5 - Load chart

Machine on tyres with forks Metric

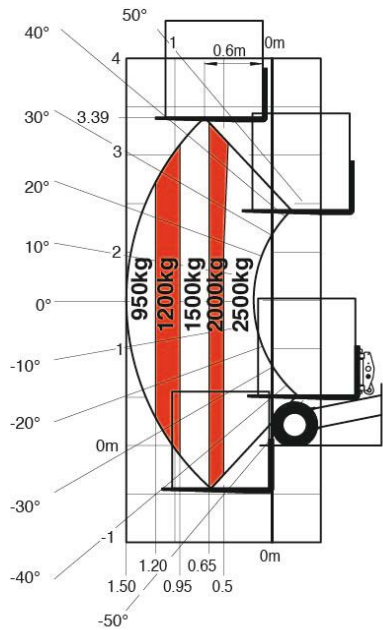

SUIVANT NORME EN 1459 annexe A.



N°285160



Siège Social
430 rue de l'Aubinière - 44150 Ancenis Cedex - France
Tel: +33(0)2 40 09 10 11 - Fax: +33 (0)2 40 09 10 97
www.manitou.com



This brochure describes versions and configuration options for Manitou products which may be fitted with different equipment. The equipment described in this brochure may be standard, optional or not available depending on version. Manitou reserves the right to change the specifications shown and described at any time and without prior warning. The manufacturer is not liable for the specifications given. For more information, contact your Manitou dealer. Non-contractual document. Product descriptions may differ from actual products. List of specifications is not comprehensive. The logos and visual identity of the company are the property of Manitou and may not be used without authorisation. All rights reserved. The photos and diagrams contained in this brochure are provided for information only.

MANITOU BF SA - Limited company with board of directors - Share capital: 39,668,399 euros - 857 802 508 RCS Nantes