

Technical sheet :

# **STACKY 14**

---



Technical characteristics		Metric	
1.1	Manufacturer		Manitou
1.2	Model Name		Stacky 14
1.3	Power source		Battery
1.4	Operator type		Companion
1.5	Max. capacity	Q	1400 kg
1.6	Load centre of gravity	c	600 mm
1.8	Load distance, centre of drive axle to fork	x	689 mm
1.9	Wheelbase	y	1200 mm
Weight			
2.1	Overall weight without tools		442 kg
Wheels			
3.1	Tyres type		Polyurethane
3.5.2	Number of drive wheels - Size of drive wheels		1 x 200x80
3.3	Number of load wheels - Size of load wheels		2 x 78x78
3.4	Number of castor wheels		1
3.4	Number of stabilizer wheels / Size of the stabilizer wheels		1 x 125x50
3.5	Number of front wheels / rear wheels		1 / 2
3.6	Front wheel gauge	b10	517 mm
3.7	Rear wheel gauge	b11	388 mm
Dimensions			
4.2	Height mast lowered *	h1	1331 mm
4.4	Max. lifting height	h3	818 mm
4.5	Height mast extended *	h4	1331 mm
4.9	Height tiller min. / max.	h14 / h14	850 mm / 1350 mm
4.15	Fork height in low position	h13	80 mm
4.19	Overall length without tools	l1	1820 mm
4.20	Length to face of forks	l2	680 mm
4.21	Overall width	b1	806 mm
4.22	Forks section / width / length	s / e / l	60 mm x 178 mm / 1150 mm
4.25	Fork spread	b5	566 mm
4.26	Distance between wheel arms/loading surfaces	b4	270 mm
4.24	Fork carriage width	b3	680 mm
4.32	Ground clearance at centre of wheelbase	m2	22 mm
4.34	Aisle width for 800 x 1200 pallet lengthways	Ast	2070 mm
4.35	Turning radius	Wa	1385 mm
Performances			
5.1	Travel speed (laden / unladen)		4.50 km/h / 5 km/h
5.2	Lifting speed (laden / unladen)		0.10 m/s / 0.18 m/s
5.3	Lowering speed (laden / unladen)		0.10 m/s / 0.07 m/s
5.7	Gradeability (laden / unladen)		5 % / 8 %
5.10	Service brake		Electro magnetic
5.11	Parking brake		Unlocking the handle
Engine			
6.1	Drive motor rating S2 60 min		0.50 kW
6.2	Lift motor rating at S3 15%		2 kW
6.3	Battery according to DIN 43531/35/36 A, B, C		Semi-Traction
6.4	Battery / Batteries capacity		24 V / 85 Ah
6.5	Battery weight (+/- 5%)		50 kg
Miscellaneous			
8.1	Type of drive control		AC
8.4	Sound level at the driver's ear according to DIN 12 053		65 dB

Stacky 14 - Dimensional drawing

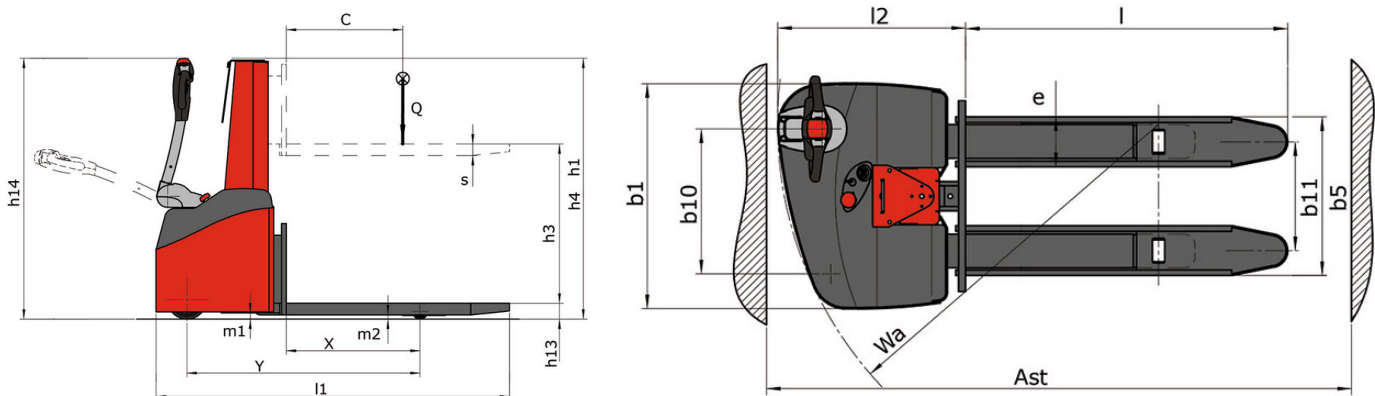



Siège Social

430 rue de l'Aubinière - 44150 Ancenis Cedex - France

Tel: +33(0)2 40 09 10 11 - Fax: +33 (0)2 40 09 10 97

[www.manitou.com](http://www.manitou.com)



This brochure describes versions and configuration options for Manitou products which may be fitted with different equipment. The equipment described in this brochure may be standard, optional or not available depending on version. Manitou reserves the right to change the specifications shown and described at any time and without prior warning. The manufacturer is not liable for the specifications given. For more information, contact your Manitou dealer. Non-contractual document. Product descriptions may differ from actual products. List of specifications is not comprehensive. The logos and visual identity of the company are the property of Manitou and may not be used without authorisation. All rights reserved. The photos and diagrams contained in this brochure are provided for information only.

MANITOU BF SA - Limited company with board of directors - Share capital: 39,668,399 euros - 857 802 508 RCS Nantes