

Technical sheet :

MT 1440 ST5



Capacities		Metric
Max. capacity		4000 kg
Max. lifting height		13.53 m
Max. outreach		9.46 m
Breakout force with bucket		7895 daN
Weight and dimensions		
Overall length to carriage	l11	6.13 m
Overall width	b1	2.42 m
Overall height	h17	2.45 m
Wheelbase	y	3.07 m
Ground clearance	m4	0.37 m
Overall cab width	b4	0.89 m
Tilt-up angle	a4	12 °
Tilt-down angle	a5	114 °
External turning radius (over tyres)	Wa1	3.97 m
Unladen weight (with forks)		10940 kg
Tyres type		Pneumatic
Standard tyres		Alliance 400/80 - 24 - 162A8
Forks length / width / section	l / e / s	1200 mm x 125 mm / 50 mm
Performances		
Lifting		16 s
Lowering		12.40 s
Extension		17.30 s
Retraction		13 s
Crowd		4.30 s
Dump		4 s
Engine		
Engine brand		Deutz
Engine norm		Stage V
Engine model		TCD 3.6L
Number of cylinders / Capacity of cylinders		4 - 3621 cm³
I.C. Engine power rating - Power (kW)		100 Hp / 75 kW
Max. torque / Engine rotation		410 Nm @ 1600 rpm
Drawbar pull (Laden)		9930 daN
Transmission		
Transmission type		Torque converter
Number of gears (forward / reverse)		4 / 4
Max. travel speed		24.90 km/h
Parking brake		Automatic parking brake
Service brake		Oil-immersed multi-discs braking on front & rear axles
Hydraulics		
Hydraulic pump type		Gear pump
Hydraulic flow / Pressure		167 l/min / 270 bar
Tank capacities		
Engine oil		10 l
Hydraulic oil		135 l
Fuel tank		140 l
DEF tank capacity		22.60 l
Noise and vibration		
Noise at driving position (LpA)		79 dB
Noise to environment (LwA)		106 dB
Vibration on hands/arms		< 2.50 m/s²
Miscellaneous		
Steering wheels (front / rear)		2 / 2
Drive wheels (front / rear)		2 / 2
Safety cab homologation		Cabin ROPS - FOPS Level 2
Controls		JSM

MT 1440 ST5 - Dimensional drawing

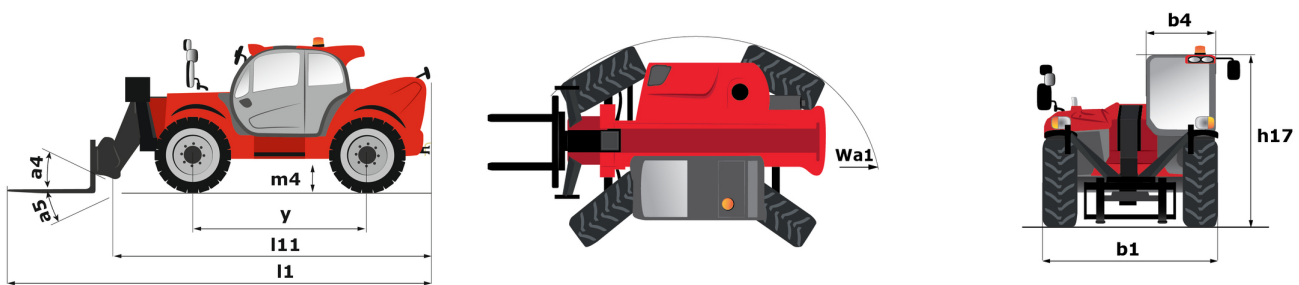

MT 1440 ST5 - Load chart

Machine on tyres with forks - with levelling Metric

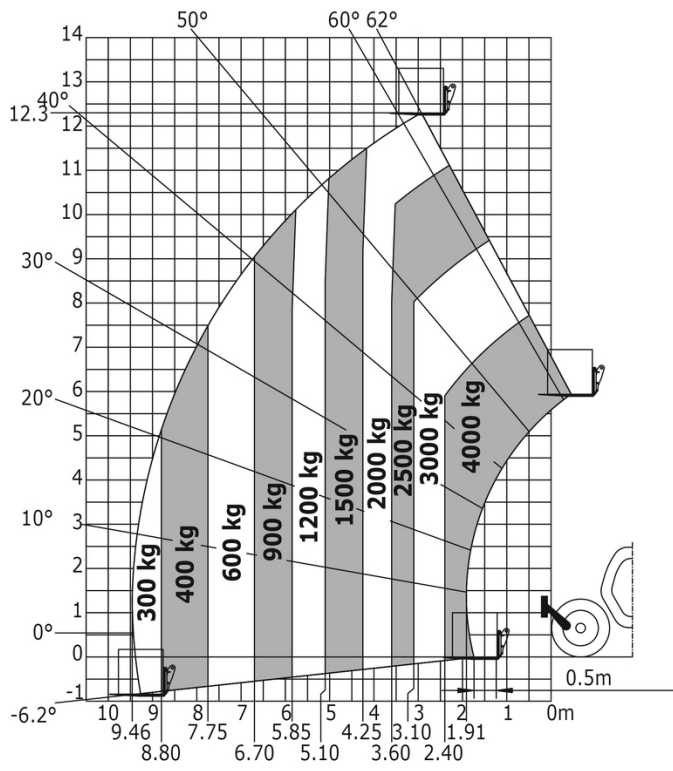

Machine on stabilizers with forks Metric

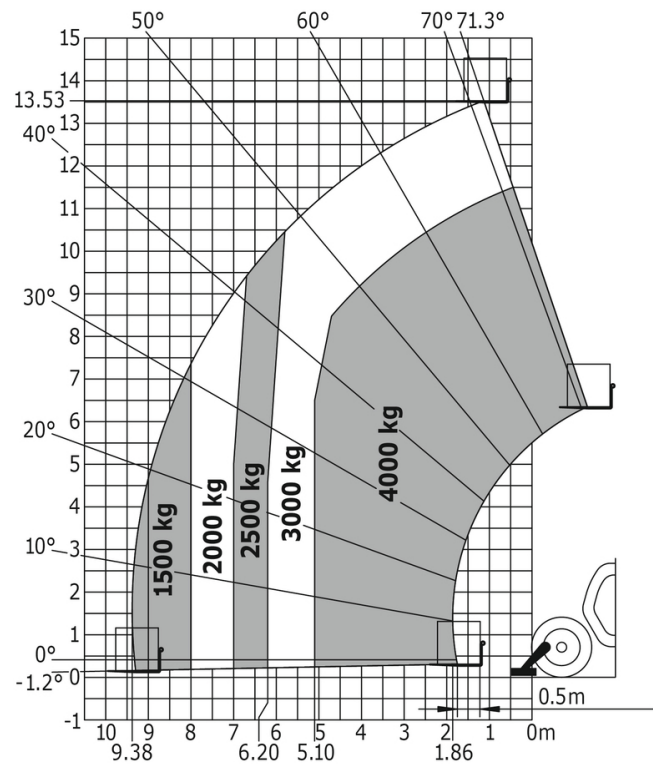



Siège Social
430 rue de l'Aubinière - 44150 Ancenis Cedex - France
Tel: +33(0)2 40 09 10 11 - Fax: +33 (0)2 40 09 10 97
www.manitou.com



This brochure describes versions and configuration options for Manitou products which may be fitted with different equipment. The equipment described in this brochure may be standard, optional or not available depending on version. Manitou reserves the right to change the specifications shown and described at any time and without prior warning. The manufacturer is not liable for the specifications given. For more information, contact your Manitou dealer. Non-contractual document. Product descriptions may differ from actual products. List of specifications is not comprehensive. The logos and visual identity of the company are the property of Manitou and may not be used without authorisation. All rights reserved. The photos and diagrams contained in this brochure are provided for information only.

MANITOU BF SA - Limited company with board of directors - Share capital: 39,668,399 euros - 857 802 508 RCS Nantes