

Technical sheet :

MI 35 GST5



	Technical characteristics		Metric
1.1	Manufacturer		MANITOU
1.2	Model Name		MI 35 G ST5
1.3	Power source		Lpg
1.4	Operator type		Sitting
1.5	Max. capacity	Q	3500 kg
1.6	Load centre of gravity	c	500 mm
1.8	Load distance, centre of drive axle to fork	x	485 mm
1.9	Wheelbase	y	1700 mm
	Weight		
2.1	Service weight		4740 kg
2.2	Weight on front axle (laden) / rear axle (laden)		7260 kg / 980 kg
2.3	Weight on front axle (Unladen) / rear axle (Unladen)		1775 kg / 2965 kg
	Wheels		
3.1	Tyres type		Super Elastic
3.2	Dimensions of front wheels		28-9-15 12
3.3	Dimensions of rear wheels		6.50-10 10
3.5	Number of front wheels / rear wheels		2 / 2
3.5.2	Number of drive wheels		2
3.6	Front wheel gauge	b10	1005 mm
3.7	Rear wheel gauge	b11	975 mm
	Dimensions		
4.1	Tilt of Mast Forward (deg) / Backward (deg)	α / β	6 / 12
4.12	Height of towing bar (coupling height)	h10	360 mm
4.19	Overall length	l1	3935 mm
4.20	Length to face of forks	l2	2785 mm
4.21	Overall width - Single wheels	b1	1225 mm
4.21	Overall width - Twinned wheels	b1	1725 m
4.22	Forks section / width / length	s / e / l	50 mm x 122 mm / 1150 mm
4.23	Fork carriage ISO 2328 (class/form) A/B		FEM 3A
4.24	Fork carriage width	b3	1100 mm
4.31	Ground clearance below mast	m1	130 mm
4.32	Ground clearance at centre of wheelbase	m2	200 mm
4.33	Aisle Width for pallets 1000 x 1200 crossways	Ast	4195 mm
4.34	Aisle width for 800 x 1200 pallet lengthways	Ast	4395 mm
4.35	Turning radius	Wa	2510 mm
4.36	Internal turning radius (over tyres)	b13	160 mm
4.7	Height of overhead guard (cabin)	h6	2130 m
4.8	Seat height/stand height	h7	1215 mm
	Performances		
5.1	Travel speed (laden / unladen)		20 km/h / 20 km/h
5.2	Lifting speed (laden / unladen)		0.43 m/s / 0.46 m/s
5.3	Lowering speed (laden / unladen)		0.47 m/s / 0.38 m/s
5.5	Drawbar pull (Laden / Unladen)		2000 daN / 1100 daN
5.7	Gradeability (laden / unladen)		20 % / 20 %
5.10	Service brake		Hydraulic
	Engine		
7.1	Engine brand / model		GCT (ex-Nissan) / GK25 LPG
7.2	Engine power according to ISO 1585		43.40 kW
7.3	Rated speed		2700 rpm
7.4	Number of cylinders / Capacity of cylinders		4 - 2488 cm ³
	Miscellaneous		
8.2	Working hydraulic pressure for attachments		160 bar
8.3	Oil flow rate for attachments		75 l/min
8.4	Measured/guaranteed mean noise level at the ear of the operator		< 80 dB

MI 35 G ST5 - Dimensional drawing

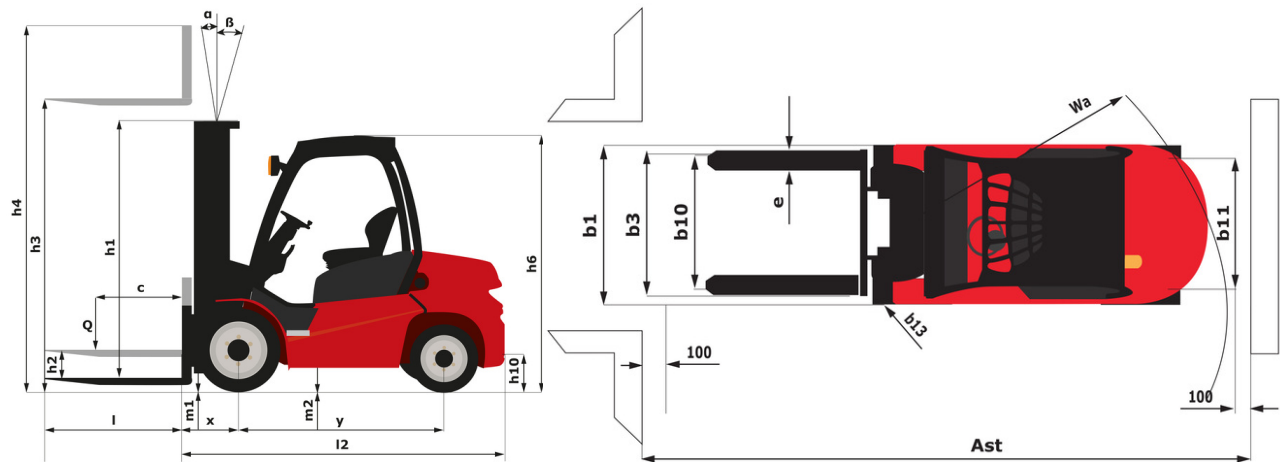

Characteristics of masts and residual capacities

Duplex with total visibility		FVD 33	FVD 37	FVD 40
h2 - Free lift	mm	145	145	145
h1 - Height mast lowered *	mm	2315	2565	2715
h3 - Lifting Height	mm	3300	3700	4000
h4 - Height mast extended *	mm	4115	4515	4815
α / β - Mast inclination (front / rear)	°	6 / 12	6 / 12	6 / 12
Residual capacity without attachment (Industrial load chart)	kg	3500	3500	3500
Residual capacity with integrated side shift (Industrial load chart)	kg	3500	3500	3500
Height at max capacity	mm	3300	3700	4000
Height at max capacity with integrated sideshift	mm	3300	3700	4000

Duplex with free lift		FLD 33	FLD 37	FLD 40
h2 - Free lift	mm	1500	1700	1850
h1 - Height mast lowered *	mm	2330	2530	2680
h3 - Lifting Height	mm	3300	3700	4000
h4 - Height mast extended *	mm	4130	4530	4830
α / β - Mast inclination (front / rear)	°	6 / 12	6 / 12	6 / 12
Residual capacity without attachment (Industrial load chart)	kg	3500	3500	3500
Residual capacity with integrated side shift (Industrial load chart)	kg	3500	3500	3500
Height at max capacity	mm	3300	3700	4000
Height at max capacity with integrated sideshift	mm	3300	3700	4000

Free lift triplex		FLT 43	FLT 45	FLT 47	FLT 48	FLT 50	FLT 55	FLT 60	FLT 65
h2 - Free lift	mm	1385	1435	1485	1535	1585	1735	1985	2135
h1 - Height mast lowered *	mm	2215	2265	2315	2365	2415	2565	2815	2965
h3 - Lifting Height	mm	4300	4500	4700	4800	5000	5500	6000	6500
h4 - Height mast extended *	mm	5130	5380	5530	5630	5830	6330	6880	7330
α / β - Mast inclination (front / rear)	°	6 / 6	6 / 6	6 / 6	6 / 6	6 / 6	3 / 6	3 / 6	3 / 6
Residual capacity without attachment (Industrial load chart)	kg	3450	3400	3300	3300	3000	2200	1600	1500
Residual capacity with integrated side shift (Industrial load chart)	kg	3450	3300	3200	3200	2900	2100	1500	1400
Height at max capacity	mm	4000	4000	4000	4000	4000	4000	4000	4000
Height at max capacity with integrated sideshift	mm	4000	4000			4000			



Siège Social
430 rue de l'Aubinière - 44150 Ancenis Cedex - France
Tel: +33(0)2 40 09 10 11 - Fax: +33 (0)2 40 09 10 97
www.manitou.com



This brochure describes versions and configuration options for Manitou products which may be fitted with different equipment. The equipment described in this brochure may be standard, optional or not available depending on version. Manitou reserves the right to change the specifications shown and described at any time and without prior warning. The manufacturer is not liable for the specifications given. For more information, contact your Manitou dealer. Non-contractual document. Product descriptions may differ from actual products. List of specifications is not comprehensive. The logos and visual identity of the company are the property of Manitou and may not be used without authorisation. All rights reserved. The photos and diagrams contained in this brochure are provided for information only.

MANITOU BF SA - Limited company with board of directors - Share capital: 39,668,399 euros - 857 802 508 RCS Nantes