

Technical sheet :

MC 18-4 ST5



Technical characteristics			Metric
1.1	Manufacturer		Manitou
1.2	Model Name		MC 18-4 ST5
1.3	Power source		Diesel
1.4	Operator type		Sitting
1.5	Max. capacity	Q	1800 kg
1.6	Load centre of gravity	c	500 mm
1.8	Load distance, centre of drive axle to fork	x	616 mm
1.9	Wheelbase	y	1900 mm
Weight			
2.1	Service weight		3590 kg
2.2	Weight on front axle (laden) / rear axle (laden)		4670 kg / 720 kg
2.3	Weight on front axle (Unladen) / rear axle (Unladen)		1660 kg / 1930 kg
Wheels			
3.1	Tyres type		Pneumatic
3.2	Dimensions of front wheels		12,5/80-18/12 SL R4
3.3	Dimensions of rear wheels		27x10-12 SKS
3.5	Number of front wheels / rear wheels		2 / 2
3.5.2	Number of drive wheels		4
3.6	Front wheel gauge	b10	1159 mm
3.7	Rear wheel gauge	b11	1176 mm
Dimensions			
4.1	Tilt of Mast Forward (deg) / Backward (deg)	α / β	12 / 10
4.7	Height of overhead guard (cabin) / Overall height of low overhead guard (Buggie version)	h6 / h6*	2155 mm / 1990 mm
4.8	Seat height/stand height	h7	1094 mm
4.19	Overall length	l1	4100 mm
4.20	Length to face of forks	l2	2950 mm
4.21	Overall width	b1	1450 mm
4.22	Forks section x width x length	s / e / l	35 mm x 100 mm / 1150 mm
4.23	Fork carriage ISO 2328 (class/form) A/B		FEM 2A
4.24	Fork carriage width	b3	1260 mm
4.31	Ground clearance below mast	m1	300 mm
4.32	Ground clearance at centre of wheelbase	m2	310 mm
4.35	Turning radius	Wa	3370 mm
Performances			
5.1	Travel speed (laden / unladen)		12 km/h / 23.50 km/h
5.2	Lifting speed (laden / unladen)		0.44 m/s / 0.44 m/s
5.3	Lowering speed (laden / unladen)		0.40 m/s / 0.40 m/s
5.5	Drawbar pull (Laden)		1800 daN
5.7	Gradeability (laden)		35 %
5.10	Service brake		Hydraulic brakes by loss of pressure
Engine			
7.1	Engine brand / model / norm		Kubota / D1803 CR E5B / Stage V
7.2	Engine power according to ISO 1585		27 kW
7.3	Rated speed		2700 rpm
7.4	Number of cylinders / Capacity of cylinders		3 - 1826 cm ³
Miscellaneous			
8.1	Type of drive control		Electronic
8.2	Working hydraulic pressure for attachments		160 bar
8.3	Oil flow rate for attachments		31 l/min

MC 18-4 ST5 - Dimensional drawing

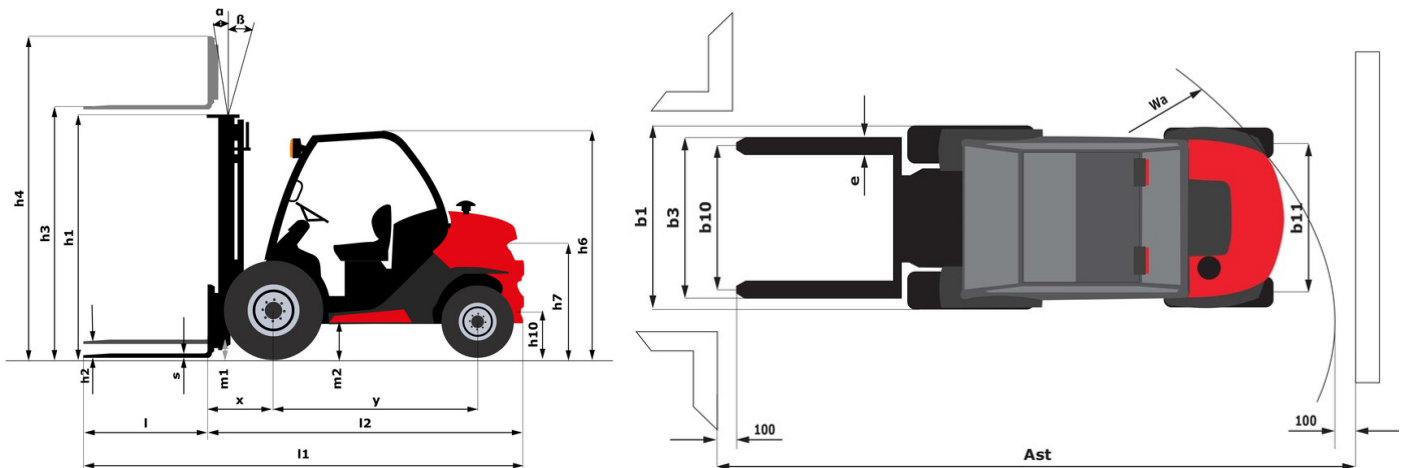

Characteristics of masts and residual capacities

Duplex with total visibility		FVD 33	FVD 37	FVD 40	FVD 45
h2 - Free lift	mm	85	85	85	85
h1 - Height mast lowered *	mm	2348	2608	2798	3048
h3 - Lifting Height	mm	3300	3700	4000	4500
h4 - Height mast extended *	mm	4018	4428	4768	5268
α / β - Mast inclination (front / rear)	°	12 / 10	12 / 10	12 / 10	12 / 10
Residual capacity without attachment (Industrial load chart)	kg	1800	1800		1100
Residual capacity with hooked-on side shift (Industrial load chart)	kg	1800	1800		1100
Height at max capacity	mm	3300	3700		3600
Height at max capacity with hooked-on sideshift	mm	3300	3700		3600

Free lift triplex		FLT 37	FLT 43	FLT 47	FLT 55
h2 - Free lift	mm	1305	1505	1655	1915
h1 - Height mast lowered *	mm	1998	2198	2348	2608
h3 - Lifting Height	mm	3700	4300	4700	5500
h4 - Height mast extended *	mm	4453	5053	5453	6253
α / β - Mast inclination (front / rear)	°	12 / 10	12 / 10	12 / 10	6 / 6
Residual capacity without attachment (Industrial load chart)	kg	1600	1000	600	
Residual capacity with hooked-on side shift (Industrial load chart)	kg	1550	1000	600	
Height at max capacity	mm	3400	3400	3400	
Height at max capacity with hooked-on sideshift	mm	3300	3400	3400	

Triplex with total visibility		FVT 33
h2 - Free lift	mm	135
h1 - Height mast lowered *	mm	1888
h3 - Lifting Height	mm	3300
h4 - Height mast extended *	mm	4048
α / β - Mast inclination (front / rear)	°	12 / 10
Residual capacity without attachment (Industrial load chart)	kg	1800
Residual capacity with hooked-on side shift (Industrial load chart)	kg	1800
Height at max capacity	mm	3300
Height at max capacity with hooked-on sideshift	mm	3300



Siège Social
430 rue de l'Aubinière - 44150 Ancenis Cedex - France
Tel: +33(0)2 40 09 10 11 - Fax: +33 (0)2 40 09 10 97
www.manitou.com



This brochure describes versions and configuration options for Manitou products which may be fitted with different equipment. The equipment described in this brochure may be standard, optional or not available depending on version. Manitou reserves the right to change the specifications shown and described at any time and without prior warning. The manufacturer is not liable for the specifications given. For more information, contact your Manitou dealer. Non-contractual document. Product descriptions may differ from actual products. List of specifications is not comprehensive. The logos and visual identity of the company are the property of Manitou and may not be used without authorisation. All rights reserved. The photos and diagrams contained in this brochure are provided for information only.

MANITOU BF SA - Limited company with board of directors - Share capital: 39,668,399 euros - 857 802 508 RCS Nantes